

## TEMPERATURE MAINTENANCE SYSTEMS

### RSV

## Anti-condensation tapes for electric motors



### Characteristics

- Very flexible.
- Maximum heat transfer.
- Damp-proof.
- Extended range of lengths and power ratings.
- Power cable: length 500 mm as standard.
- Voltage 230 V as standard (115 V on request).
- Approved for use in motors running in explosive atmospheres.
- ATEX certificate: Sira N° 02ATEX3410U.
- IECEx certificate: SIR 10.0151U.
- Special production on request.
- Production on request.

### Applications

RSV heating tapes are specially designed for electric motors to prevent condensation.

These elements are ready to be incorporated into the motor coil with their fibre glass braid.

RSV tapes are practical to use and very efficient.

They transfer a maximum amount of heat as they are in direct contact with the stator. RSV tapes are generally energised when the motor stops.

To ensure that these heating elements enjoy a long service life, we recommend using a control device.

### Standards

- |                        |                   |
|------------------------|-------------------|
| CEI 62395-1            | NF EN 60079-30-1  |
| CEI 62395-2            | NF EN 60079-7     |
| CAN/CSA-C22.2 n°130-03 | NF EN IEC 60079-0 |

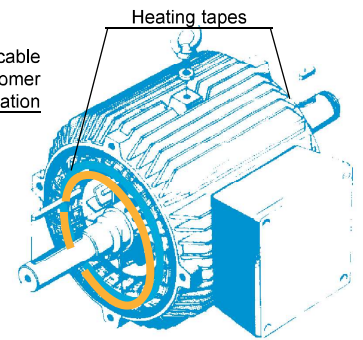
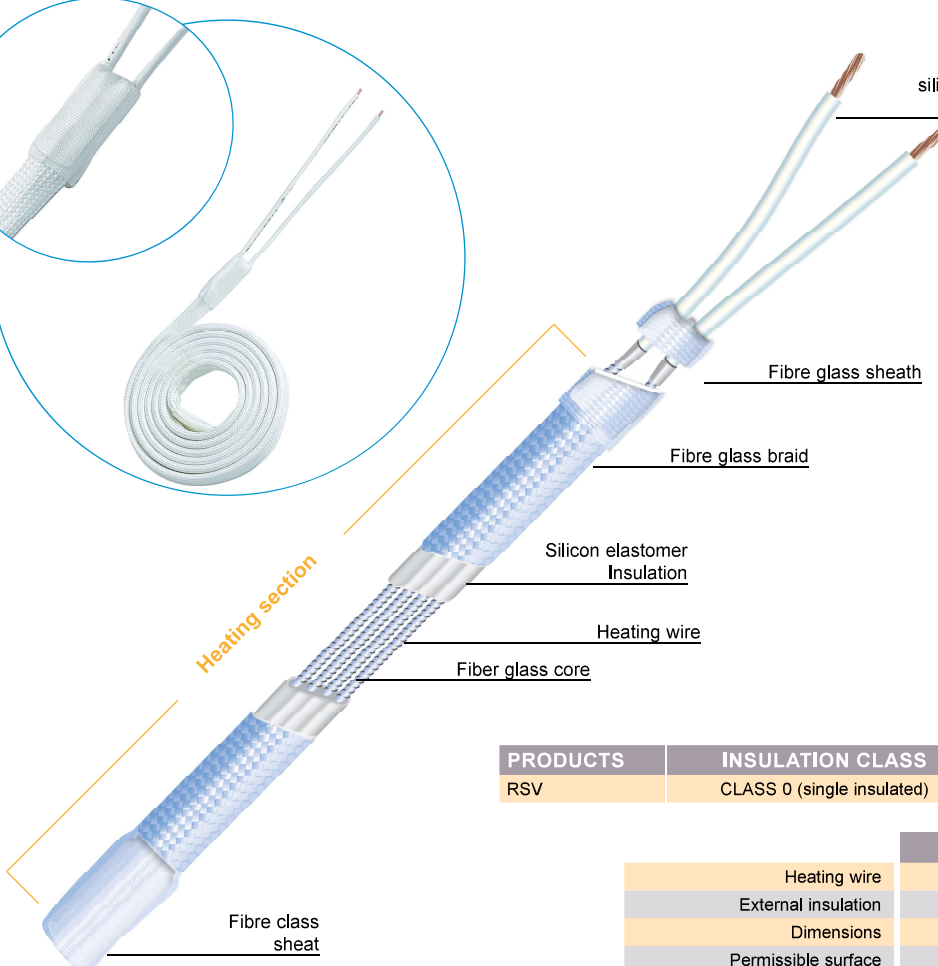
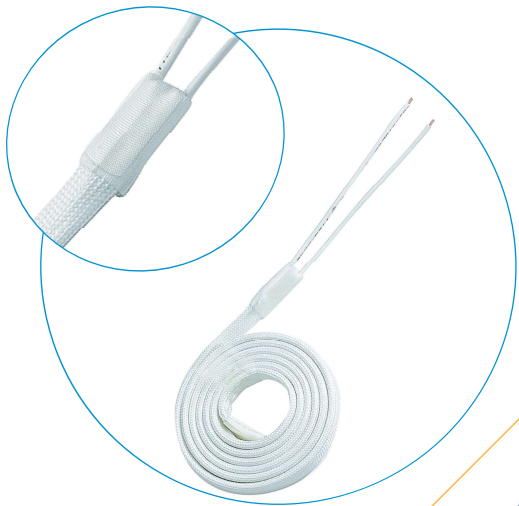

### Standard models

Length (m)	Power (W)
0.30	25
0.43	25
0.68	40
0.79	26
1.01	42
1.06	50
1.47	65
1.70	75
1.70	100
1.85	100

PRODUCTS	INSULATION CLASS
RSV	CLASS 0 (single insulated)

RSV	
Heating wire	Nickel-Copper or Nickel-Chrome
External insulation	Fibre glass braid
Dimensions	3 x 11 mm
Permissible surface temperature	from - 70°C to + 200°C
Tolerances	Power: ± 10 %
Connection and end insulation	Fibre glass sheath
Ingress protection code	IP53
Minimum bending radius	6 x the thickness

### Use

Heating tapes are series resistors. Consult the pages of the catalogue devoted to the corresponding general operating principles, general instructions for use and accessories.

#### FLEXELEC S.A.S

10, rue des frères Lumière  
Z.A. du Bois Rond  
69720 ST BONNET DE MURE - FRANCE  
Tél : + 33 (0)4.72.48.30.90  
E-mail : flexelec@omerin.com

#### FLEXELEC Dept

OMERIN ASIA Pte Ltd  
51 Goldhill Plaza #08-11  
SINGAPORE 308900  
Tel : + 65.6255.4778  
Fax : + 65.6255.4779  
E-mail : sales@omerin.com.sg

#### FLEXELEC (UK) Ltd

Unit 11 Kings Park Industrial Estate  
Primrose Hill - KINGS LANGLEY  
Hertfordshire - WD4 8ST - UK  
Tel : + 44 (0) 1923.274477  
Fax : + 44 (0) 1923.270264  
E-mail : sales@omerin.co.uk

#### FLEXELEC Dept

OMERIN GmbH  
Buchwiese 16  
D-65510 IDSTEIN - GERMANY  
Tel : + 49 (0) 6126.94.31-0  
Fax : + 49 (0) 6126.83.999  
E-mail : omeringmbh@omerin.com